

XEN-1200 compass chip

1	Introduction.....	2
1.1	Short description.....	2
2	Technical data.....	3
2.1	XEN-1200 Specifications.....	3
2.2	Typical Characteristics of XEN-1200.....	4
2.3	Typical operation.....	5
3	Application: compass	9
3.1	Compass system.....	9
3.2	Calibration.....	11
3.3	Compass packaging	11
3.4	Position and linear packaging	14
4	Extended description and general notes on use	15
4.1	Theory of operation.....	15

1 Introduction

1.1 Short description

Features

- Digital SPI output
- Sub- μ T accuracy
- One degree accuracy
- No external components
- No hysteresis
- High linear range
- Unaffected by magnetic field overloading
- Small size
- Low-power, low offset

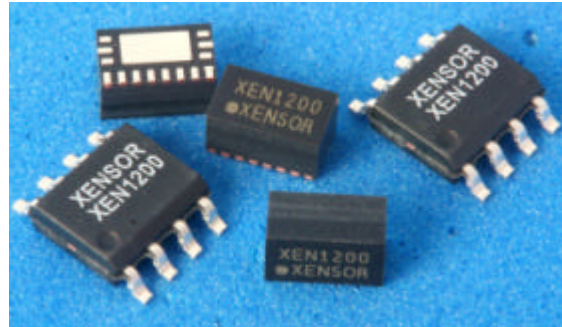

Applications

- Instruments: Portable/GPS
- Compass: boat/car/handheld
- Watches: diver/navigation
- Mobile phones
- Robotics orientation
- Inertial navigation
- Magnetic position

Description

The XEN-1200 is a revolutionary magnetic field transducer with an accuracy better than 1 μ T (Patent NL-1025089), and a linear field range of 10.8 mT. It contains an instrumentation opamp, ADC, and a digital SPI interface. It can be connected to a μ P without any external components.

One XEN-1200, packaged in SO8, can be used for linear field measurements or as a magnetic position sensor.

Two XEN-1200, each in SFN8 packages on 90° angle, form a compass solution as an alternative to magneto-resistive and inductive sensors / sensor bridges.

The XEN-1200 sensor is sensitive to a magnetic field applied perpendicularly to the ASIC top surface.

Figure 1.1 XEN-1200 scheme with Quad Hall plate sensor

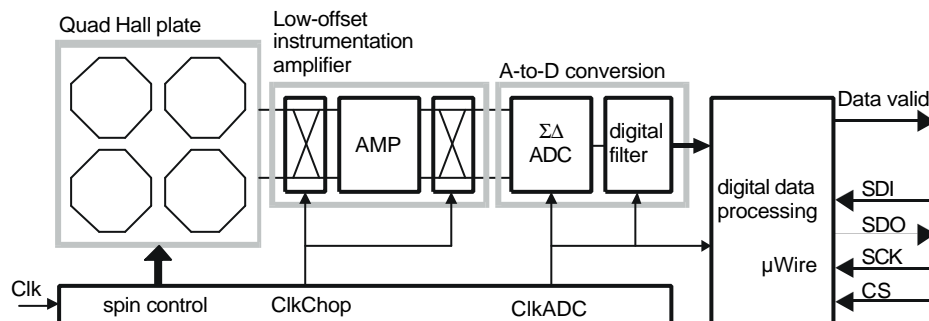

2 Technical data

2.1 XEN-1200 Specifications

Parameters	conditions	min	typ	max	units
Power supply					
VDD		4.75	5	5.25	V
IDD		4.2		4.7	mA
Temperature range					
operating range		-30		+100	°C
Output					
sample rate	@ 1MHz clock		7.7		Hz
resolution (LSB)			0.33		μT
range		-10.8		10.8	mT
Clock input					
CLK (master ADC clock)		900	1000	1300	KHz
SCK (SPI serial shift clock)			400		
Magnetic sensor					
offset	@ 25°C, 1 MHz		0.5		μT
stability	1 Month test		0.01		μT
hysteresis			0		μT
non-linearity	@ 1MHz clock		0.01		% of FS
offset temperature drift			0.007		μT/°C
gain temperature drift			250		ppm/°C
gain supply sensitivity			1		%/V
gain mismatch			±2		% of FS
Noise performance XEN-1200					
magnetic noise density	@ 25°C, 1MHz		0.3		μT/√Hz
heading noise density			0.8		degrees/√Hz
Noise performance XEN-1200LN					
magnetic noise density	@ 25°C, 1MHz		0.1		μT/√Hz
heading noise density			0.2		degrees/√Hz

Magnetic Flux Density: 100 micro Tesla (μT) = 1 gauss (G)

Magnetic Field: 1 oersted (Oe) = 79.58 amperes/meter (A/m)

100 000 gamma = 1 Oe = 79.58 A/m

Note 1: in air: 1 Oe = 1 G = 100 μT

Note 2: XEN-1200LN is the low noise version of the XEN-1200

2.2 Typical Characteristics of XEN-1200

Figure 2.1 Drift test (μT) (1 month) (@1 MHz , 5V)

Fout! Ongeldige koppeling.

Figure 2.2 Offset (μT) versus temperature (@1 MHz , 5V)

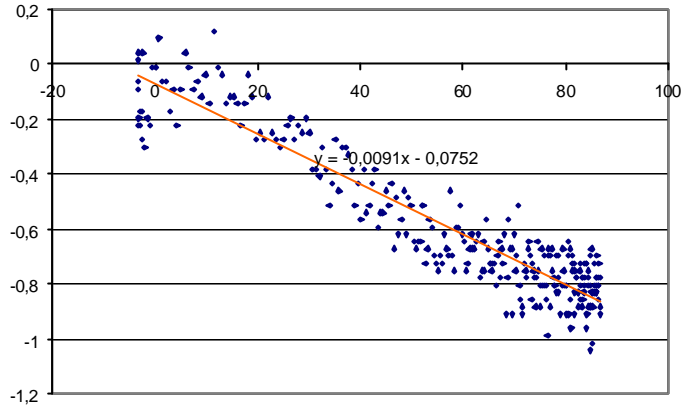
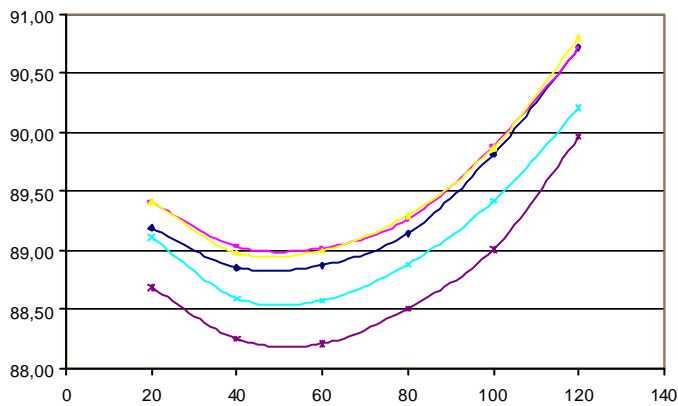
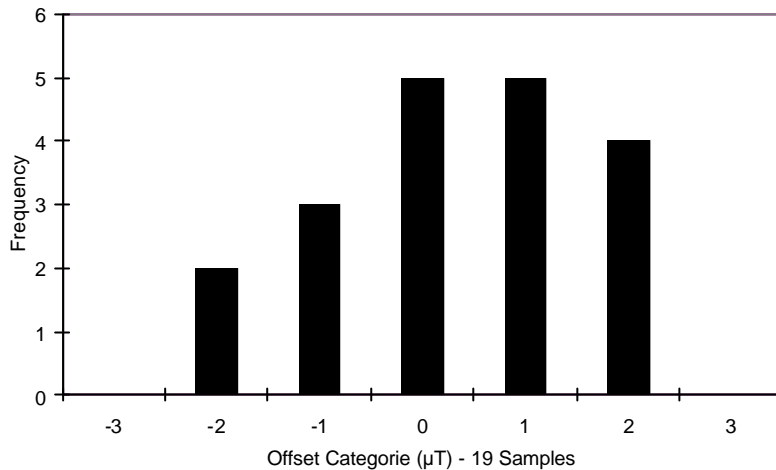

Figure 2.3 Sensitivity temperature drift (@1 MHz , 5V)



¹ Note that this temperature dependency does not affect the compass equations because signal levels are relative.

Figure 2.4 Offset distribution(μT) (@1 MHz , 5V)



2.3 Typical operation

Power supply decoupling

The XEN-1200 is a mixed-mode ASIC designed for use in combination with digital devices, such as microcontrollers, sharing the same power supply. Adequate decoupling will be beneficial for noise and offset performance of the chip. A single 100nF capacitor between VDD and ground is recommended.

Design procedure

The XEN-1200 ASIC has SPI/microwire as standard digital output, with an additional data valid signal which can be used for interrupt routines.

Figure 2.5 Quad Hall plate scheme

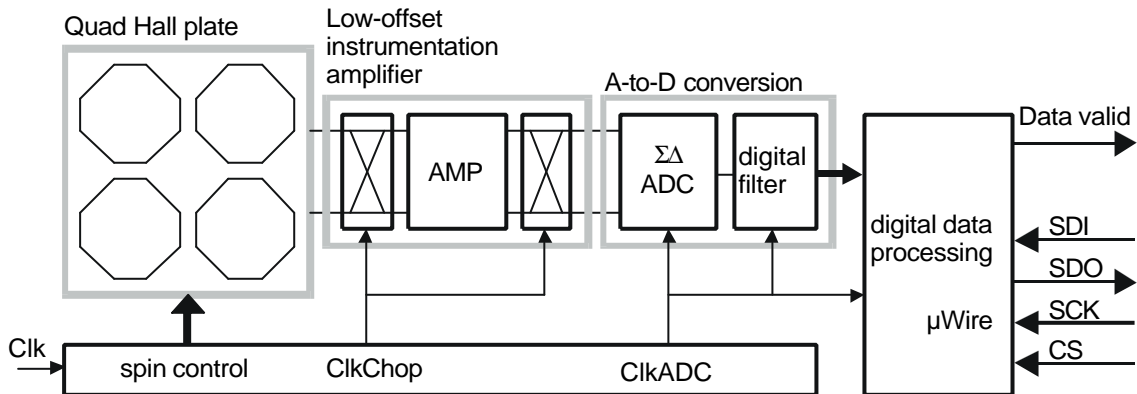

SPI/microwire operation

The XEN-1200 ASIC has a serial output in a standard SPI/microwire format. It is suitable for direct connection with the standard serial UART of a microprocessor.

The XEN-1200 indicates the availability of new data with a data-valid flag, which is pulled down on a negative clock edge of CLK and stays low for one period of CLK. In this period the new data of the ADC is loaded in the SPI shift register. The signal CS should be high during this period. After the data valid flag goes up again, the data is valid and as shown in Fig. 2.6 the XEN-1200 can be addressed by the μ P by pulling the Chip Select (CS) pin low during the data transmission. On control of the Serial Clock (SCK) the ASIC transmits two bytes in a RS232 format. The SDO data changes on the negative clock edge of SCK, so the μ P should clock it in on the positive edge.

When using a hardware interface, according to the standards for SPI transmission protocol, the SPI mode should be set to 01, that is SKP = 0, and SKE = 1 (SKP = SCK polarity, SKE = SCK edge). Also note that hardware interfaces usually read the data per byte, and that enough bytes have to be read and filtered bit-wise to decode the RS232 format.

Two bytes remain of which bit 15 is the MSB and bit 0 is the LSB¹. The two bytes are encoded with 2's-complement as shown in table 2.1. The LSB corresponds to 0.33 μ T, which gives the XEN-1200 a range between -10.8 mT and + 10.8 mT.

Figure 2.6 SPI/microwire transmission

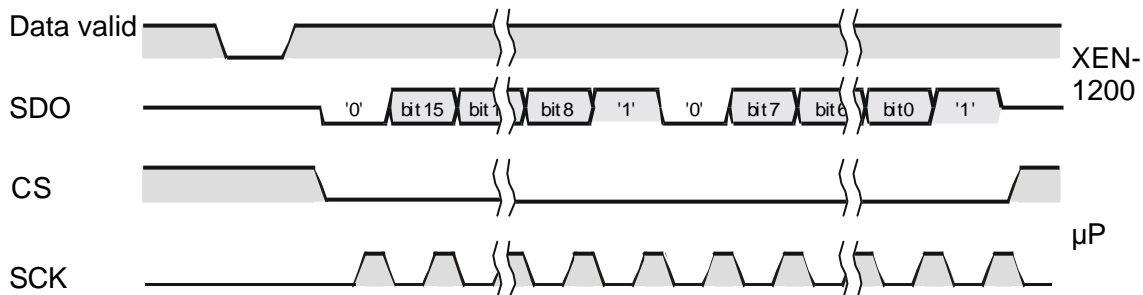

Table 2.1 2's-complement encoding of data bytes

LSB's	HEX code	Field strength
+ 2 ¹⁵ -1	0x7FFF	10.8 mT
+ 255	0x00FF	84.2 μ T
+ 1	0x0001	0.33 μ T
0	0x0000	0
-1	0xFFFF	-0.33 μ T
-255	0xFF01	-84.2 μ T
- 2 ¹⁵	0x8000	-10.8 mT

¹ MSB = most significant bit, LSB = least significant bit

Data valid flag

The data valid pin is a multi purpose in and output pin. Used as output only it defines the moments of the start and stop of one conversion period of the AD converter. It can also be used as input pin for reset or for synchronisation purposes. If the pin is pulled down by external control, the ASIC resets itself and waits till the data valid pin goes up again. At the first positive clock pulse of CLK the ASIC then starts the AD conversion cycle. In this way a μP can exactly control the moment of A-to-D conversion. This can be very convenient when external interferences have to be avoided.

Figure 2.8 Normal datavalid and reset by the μP

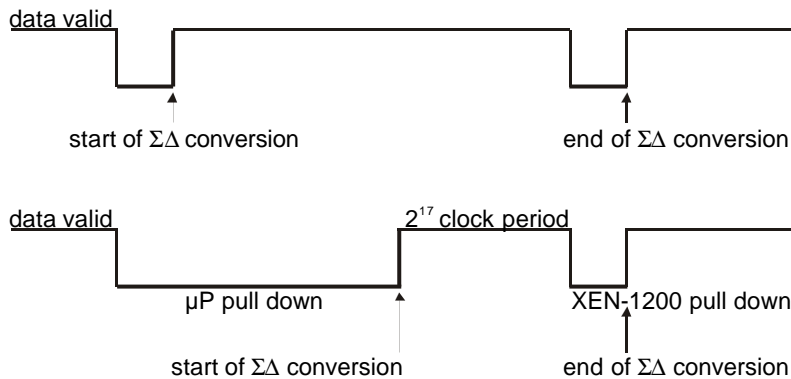

When more then one ASIC is used in one system, like for a 2D or 3D compass, the data valid pins should be connected together in which case the chip with the first data valid flag resets the other and signals output will be completely synchronized from then on.

Fig. 2.9 Synchronisation of two ASICs

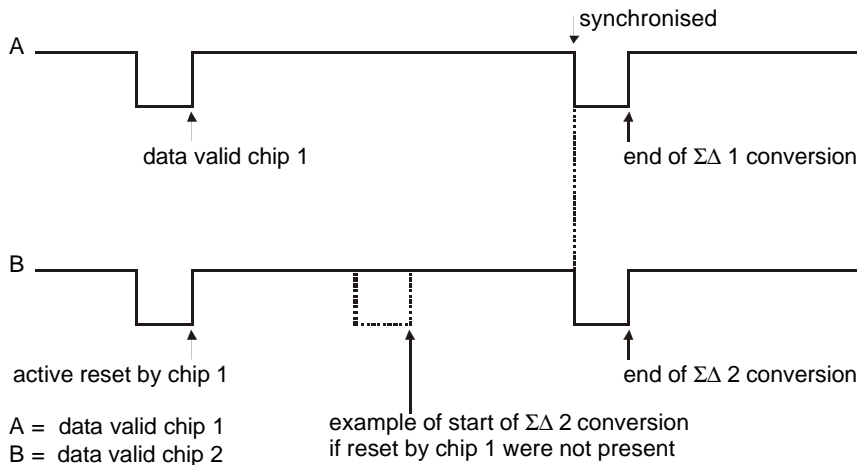

Operation of ADC

The conversion speed of the ADC or signal output rate of the ASIC can be controlled by CLK. In general the update rate is defined as 2^{17} clock periods.

Table 2.1 Conversion

CLK frequency (kHz)	conversion time (s)	conversion frequency (Hz)
900	0.15	6.87
1000	0.13	7.63
1311	0.10	10.00

During one conversion period of the ADC the magnetic signal is continuously integrated. This offers an excellent interference rejection for high-frequency noise. By choosing the total integration time as a multiple of the power supply frequency of 50 or 60 Hz, like is obtained with CLK frequency of 1311 kHz, an excellent normal mode rejection ratio can be obtained as well.

The bandwidth of a conversion for sine shaped inputs is shown in Figure 2.10. Sine shaped magnetic signals are for example obtained by multiple magnetic targets, such as gear tooth or a circle movement of a compass in the earth magnetic field.

Note, that when used to determine the vector of the earth magnetic field, the angle will not change with the magnetic signal frequency, because both sine and cosine signals are reduced equally with increased speed.

Figure 2.10 Filter characteristics for sine shape signals

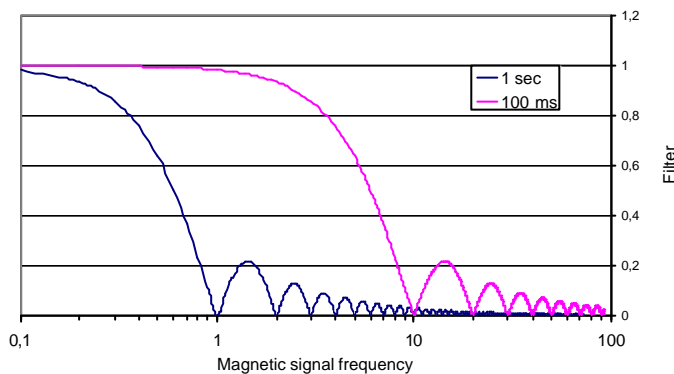

3 Application: compass

3.1 Compass system

Two ASICs for compass system

In order to obtain heading information, at least two components of the magnetic field vector must be measured. Since the sensitive axis of the XEN-1200 is perpendicular to the sensor surface, two sensors are required, placed at a 90° angle with each other and the PCB. This is obtained using 2 SFN8 packages (Single Flat No leads, 8 contacts) at a 90° angle.

Figure 3.1 Two XEN-1200 for X-vector and Y-vector connected to a μP

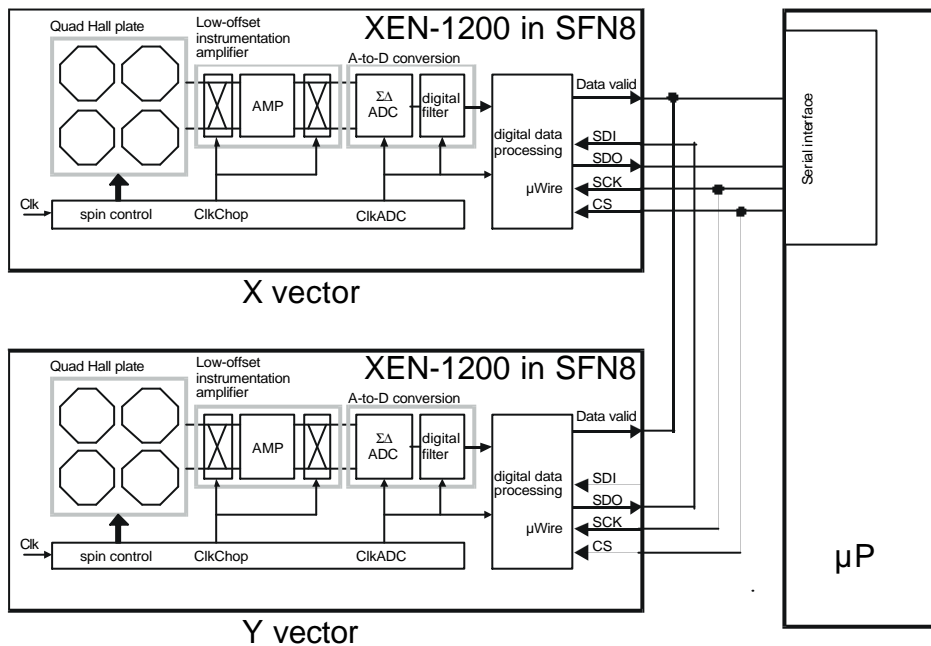

As shown in Fig. 3.1, the SDO pin of the Y-vector is connected to the SDI pin (serial data in) of the X-vector, and the SDO pin of the X-vector to the μP . The SDI pin of the Y-vector remains unconnected or, in case of a 3D compass, has to be connected to the SDO of the Z-vector. The remaining six pins are connected pin-wise together.

The SPI interface of the X-vector is connected to the μP and 4 bytes can be read out sequentially, according to section 2.3. The first 2 bytes contain the X-vector, the second 2 bytes contain the Y-vector.

Fig. 3.2 shows a PCB connection scheme for two SFN8 packages, which are connected in the way described earlier. The North arrow in the middle indicates the heading of this configuration.

In Fig 3.3. the compass output signals of this PCB configuration are shown, while turning a full circle clockwise, starting from N to E to S to W.

Figure 3.2 Example of PCB connection scheme for two SFN8 packages

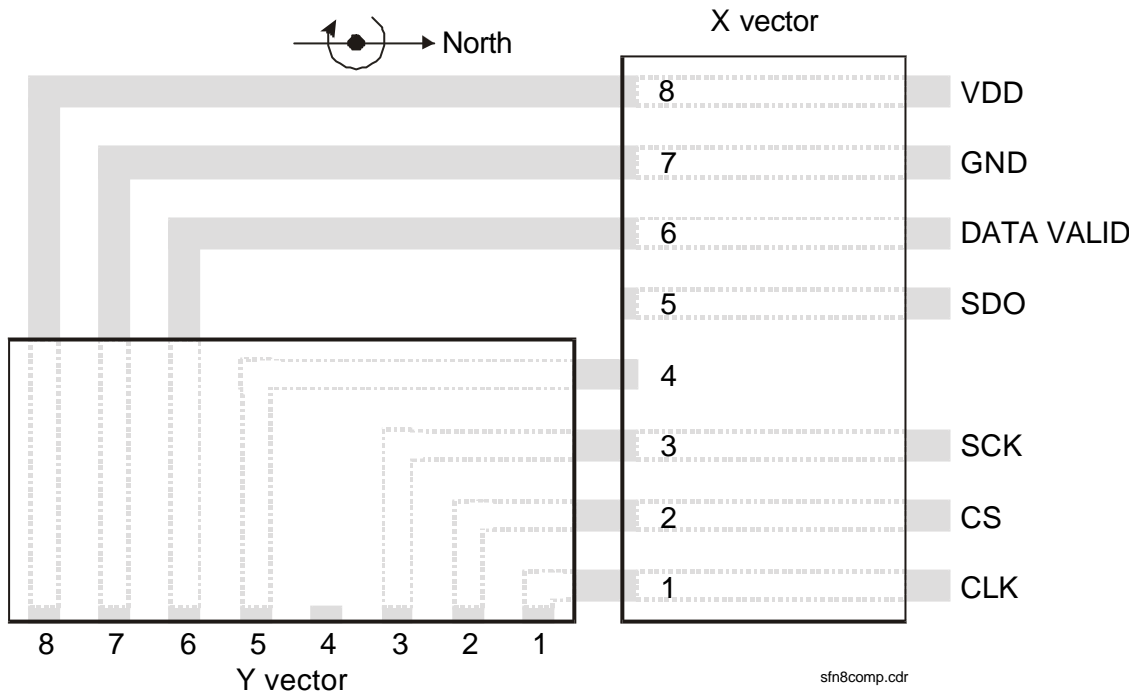

In Fig. 3.3 the signals from the XEN-1200 sensors represent the X- and Y-vectors of the earth magnetic field in μT under a full circle in the X-Y plane of the compass: clockwise rotation from N to E to S to W. The heading can be calculated with the following formulas.

Figure 3.3 Compass output

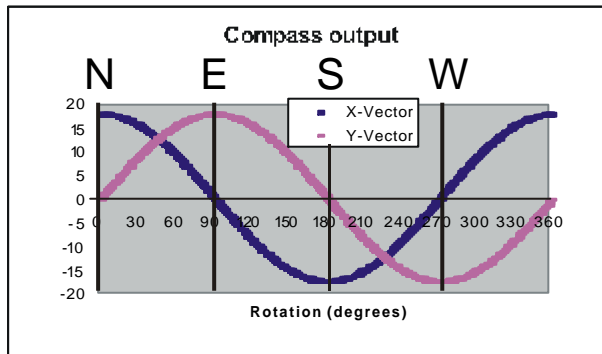

Compass heading calculation

Condition	Calculation
$H_y > 0$	$90 - \arctan(H_x/H_y) * 180/\pi$
$H_y < 0$	$270 - \arctan(H_x/H_y) * 180/\pi$
$H_y = 0, H_x < 0$	180
$H_y = 0, H_x > 0$	0

3.2 Calibration

Compensating for nearby ferrous effects

The XEN-1200 component has very accurate magnetic readings. The SFN8 package does not contain magnetic material. For correct measurements, the recommended minimum distance to other electronic components is 1 cm. In the absence of distortion effects on the earth magnetic field by ferrous materials, the heading can be calculated without prior calibration.

In case the compass is mounted in the neighborhood of ferrous materials it is recommended to compensate the system for the distortion of the earth magnetic field.

Ferrous materials which have a permanent position to the sensors can be calibrated (for instance a car with build-in sensors). Materials which do not have a permanent position to the sensors affect the magnetic vector itself and cannot be corrected for by any compass algorithm (for instance the surroundings of the car).

The calibration procedure consists of a calibration reading of a full circle made in the earth magnetic field and fitting the measured cosine (X-vector) and sine (Y-vector) signals to ideal polar coordinates. The fit parameters are then stored and used in heading calculations.

3.3 Compass packaging

XEN-1200 Package definition: SFN8

Pin	name	functionality
1	CLK	Master ADC C Lock digital input. This is the ADC clock frequency and determines the speed of the module. Typical clock frequency is 900-1300 kHz. With 1311 kHz the data output rate is 10 Hz.
2	CS	(microwire) C hip S elect digital input. The device is selected when this input is low. A high level deselects the device and forces SDO into tri-state mode. It should be high when data valid is low.
3	SCLK	S erial s hift C lock digital input. This clock determines the speed of the SDO shift register.
4	SDI	S erial D ata digital I nput pin.
5	SDO	S erial D ata digital O utput pin. Data is shifted out on the negative SCK edge. SDO changes to tri-state when CS is high.
6	DataValid	The d ata v alid pin is pulled down when the internal shift register is refreshed with new data. It can be used as an interrupt poll for the μ P. Also the μ P can reset the ASIC by pulling the pin down.
7	GND	Common Analog and Digital G round.
8	VDD	Common Analog and Digital +5 V P ower connection.

Figure 3.3 SFN8 package, 3D view
(Single Flat No leads, 8 contacts)

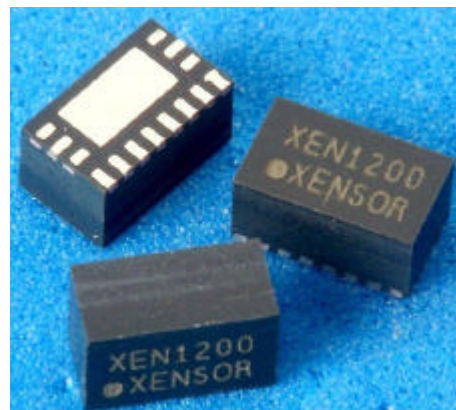
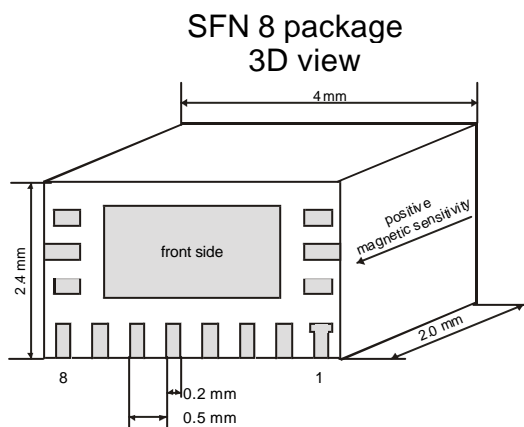

Xensor Integration bv

Distributieweg 28
2645 EJ Delfgauw
The Netherlands

Phone +31 (0)15-2578040
Fax +31 (0)15-2578050
Email info@xensor.nl

Founded 18 May 1988
Trade reg. 27227437
Site www.xensor.nl

Smart Sensor Devices

ABN-AMRO 60 50 40 311
IBAN NL42ABNA0605040311
VAT NL 009122746 B01

Footprints SFN8, horizontal (H) + vertical (V)

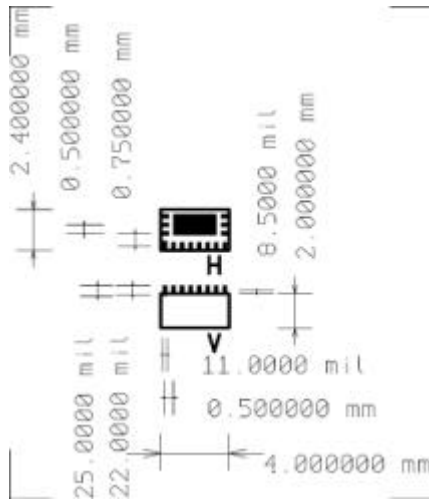

3D compass on PCB (3x XEN-1200)

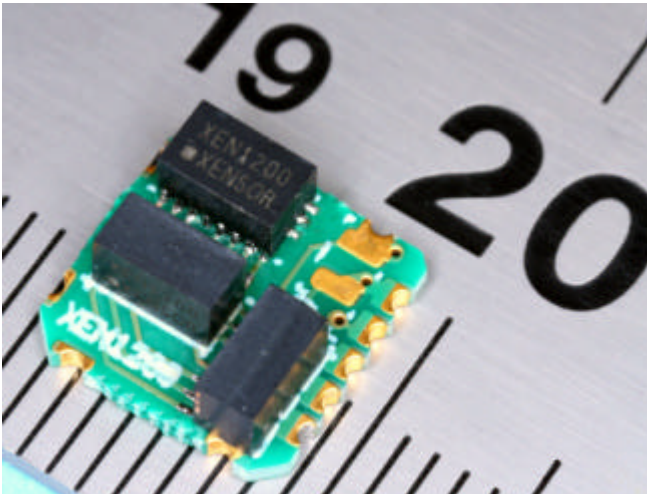

LCC-20 footprint: 8.89x8.89x3.2 mm³

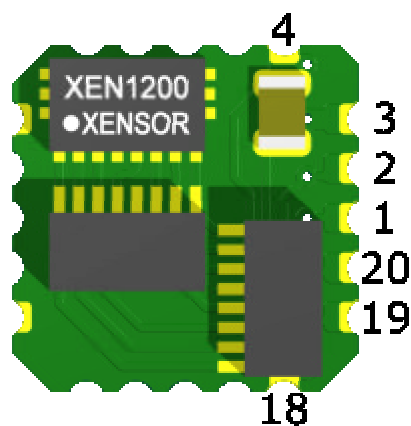
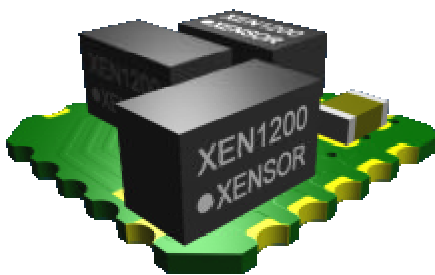

Xensor Integration bv

Distributieweg 28
2645 EJ Delfgauw
The Netherlands

Phone +31 (0)15-2578040
Fax +31 (0)15-2578050
Email info@xensor.nl

Founded 18 May 1988
Trade reg. 27227437
Site www.xensor.nl

Smart Sensor Devices

ABN-AMRO 60 50 40 311
IBAN NL42ABNA0605040311
VAT NL 009122746 B01

On the 3D compass board, 3 of the XEN-1200 sensors in SFN8 have been connected in series (connecting SDO to SDI). Thus, to get the data for all sensors, one has to clock 60 bits from the micro wire interface.

The bare 3D compass board is shaped as the footprint of a LCC-20. On this footprint all signals but SDI are available at the following pins:

XEN-1200 Package definition: 3D compass

Pin	name
1	SDO
2	DataValid
3	GND
4	VDD
5 .. 17	Not available / not connected
18	CLK
19	CS
20	SCLK

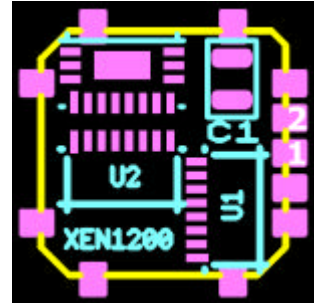

When mounted on a test board, these signals are available on the FFC/FPC connector at the following pins:

XEN-1200 Package definition: 3D compass mounted on test board

Pin	name
1	CLK
2	SCLK
3	CS
4 .. 6	not connected
7	SDO
8	DataValid
9	GND
10	VDD

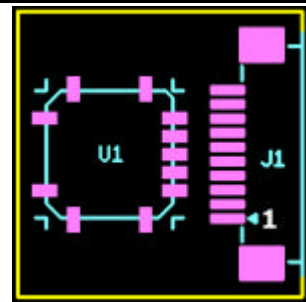

3.4 Position and linear packaging

For position applications, the XEN-1200 ASIC is sold in SO-8 package. The SO-8 package can be slightly magnetized. Magnetisation influences the offset of the sensor, but this is not important for the position sensing application.

XEN-1200 Package definition: SO-8

Pin	functionality
1	CS (microwire) Chip Select digital input. The device is selected when this input is low. A high level deselects the device and forces SDO into tri-state mode. It should be high when data valid is low.
2	NC Do not connect.
3	SDO Serial Data digital Output pin. Data is shifted out on the negative SCK edge. SDO changes to tri-state when CS is high.
4	RST / DATA VALID The data valid pin is pulled down when the internal shift register is refreshed with new data. It can be used as an interrupt poll for the μ P. Also the μ P can reset the ASIC by pulling the pin down.
5	GND Common Analog and Digital Ground.
6	VDD Common Analog and Digital 5 V Power connection.
7	CLK Master ADC CLoCK digital input. This is the ADC clock frequency and determines the speed of the module. Typical clock frequency is 900-1300 kHz. With 1311 kHz the data output rate is 10 Hz.
8	SCK Serial shift CLoCK digital input. This clock determines the speed of the SDO shift register.

dimensions: mm

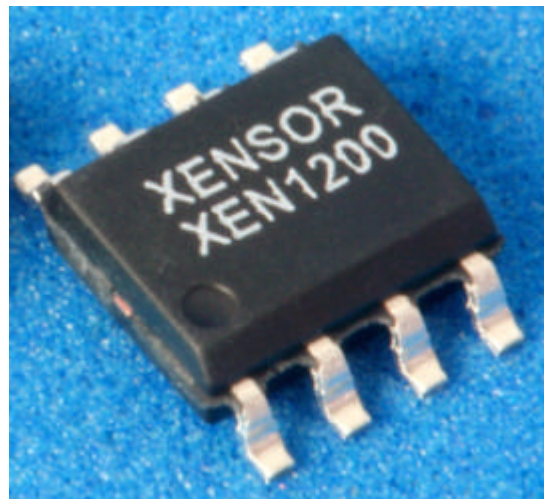
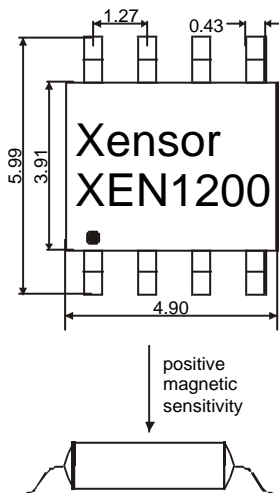

4 Extended description and general notes on use

4.1 Theory of operation

The XEN-1200 ASIC overcomes many of the drawbacks associated to magneto-resistive, fluxgate and magneto-inductive sensor technologies. The XEN-1200 does not require (re)calibration, it does not need demagnetizing coils, is insensitive to magnetic field overloading and offers a very large linear range.

The XEN-1200 sensor has intrinsic low and very stable offset ($< 1 \mu\text{T}$), a factor of 100-1000 better than regular commercial Hall sensors. It is the first known Hall sensor that is capable of measuring the Earth magnetic field strength, and so forms an ideal component for compassing applications, but is also well suited for magnetic position sensing.

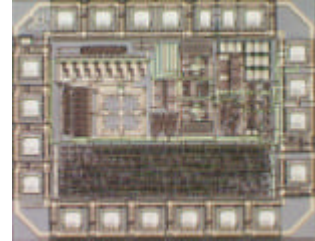

Because of the compatibility to standard CMOS technology, the XEN-1200 is equipped with an on-chip instrumentation amplifier, analog-to-digital converter and logic to provide a convenient digital output signal.

The XEN-1200 sensor combines a highly accurate spinning-current Hall sensor with instrumentation circuitry to maximize sensitivity while minimizing noise and offsets.

Various static compensation techniques have been applied to the Hall sensor element to result in extremely low offset levels.

The XEN-1200 uses four n-well Hall plates that are interconnected as a quad. This quad Hall plate compensates for mechanical (metal/packaging) stresses, doping gradients and mask misalignments caused by processing variations.

The quad Hall plate also compensates for thermally induced signals (Peltier, Seebeck).

Furthermore, the quad Hall plate compensates for magnetic-induced signals that are caused by the current-drive lines that are connected to the sensor element.



The voltage across the Hall plates is amplified by a chopper-stabilized instrumentation amplifier. This amplified signal passes an on-chip S²-modulator which runs at a frequency of 900-1300 kHz. The bitstream is processed by on-chip decimation filters and is made available to the user through SPI/microwire.

Conditions: Use of sensors for industrial applications is subjected to patent rights. Xensor Integration assumes no liability arising from violation of these rights

Warranty: Xensor Integration warrants its products against defects in materials and workmanship for 12 months from date of shipment. Products not subject to misuse will be replaced or repaired. The foregoing is in lieu of all other expressed or implied warranties. Xensor Integration reserves the right to make changes to any product herein and assumes no liability arising out of the application or use of any product or circuit described or referenced herein.

Xensor Integration bv

Distributieweg 28
2645 EJ Delfgauw
The Netherlands

Phone +31 (0)15-2578040
Fax +31 (0)15-2578050
Email info@xensor.nl

Founded 18 May 1988
Trade reg. 27227437
Site www.xensor.nl

Smart Sensor Devices

ABN-AMRO 60 50 40 311
IBAN NL42ABNA0605040311
VAT NL 009122746 B01